

Design of Electrical Power Telemetry System

Mohanad Abdulhamid¹, and Makhanu Symon²

¹AL-Hikma University, Iraq, e-mail: moh1hamid@yahoo.com

²University of Nairobi, Kenya, e-mail: researcher12018@yahoo.com

Abstrak— Secara tradisional, pembacaan meter energi dilakukan oleh operator manusia yang bergerak dari rumah ke rumah untuk mengumpulkan bacaan. Latihan ini membutuhkan tenaga operator yang sangat banyak dan banyak waktu untuk mencapai pembacaan meter yang lengkap di area tertentu. Makalah ini berusaha untuk menghilangkan masalah ini dengan menggunakan sistem telemetering. Dengan sistem ini, daya dapat diukur dari jarak jauh. Untuk mencapai hal ini, pembacaan dari pengukur energi di lokasi diproses oleh perangkat mikrokontroler yang kemudian mengirimkan informasi konsumsi energi ke modul Global System Mobile (GSM). Modul GSM kemudian mengirimkan informasi ini menggunakan gelombang mikro ke pelanggan seluler tertentu yang menerimanya dalam bentuk Layanan Pesan Singkat (SMS). Pembacaan juga ditransmisikan ke sistem telemetering berbasis web melalui server. Di situs jarak jauh, komputer jarak jauh yang dapat mengakses internet dapat memperoleh data dari server melalui internet. Mikrokontroler dikembangkan sedemikian rupa sehingga mencapai komunikasi antara meteran energi dan server tertentu menggunakan protokol Transmission Control Protocol (TCP). Program perangkat lunak juga dikembangkan untuk memfasilitasi transfer data ke pengguna di situs jarak jauh. Dengan sistem telemetering berbasis web yang terkoneksi dengan internet, pengukuran energi listrik dapat diakses secara global. Efisiensi saluran transmisi penting untuk keberhasilan sistem telemetering berbasis SMS dan web.

Kata kunci : Sistem telemeter; situs jarak jauh; GSM

Abstract— Traditionally, reading of energy meters is done by human operators who move from house to house collecting readings. This exercise requires huge labor operator numbers and a lot of time to achieve complete reading of meters in a particular area. This paper endeavors to do away with this problem by using a telemetering system. With this system, power can be measured from a remote site. To achieve this, readings from an energy meter on site are processed by a microcontroller device that then sends the energy consumption information to a Global System Mobile(GSM) module. The GSM module then sends this information using microwaves to a particular mobile subscriber who receives it in the form of an Short Message Service(SMS). The reading is also transmitted to a web based telemetering system through a server. In the remote site, a remote computer which can access the internet is able to obtain data from the server through the internet. The microcontroller is developed in such a way that it achieves communication between the energy meter and the particular server using Transmission Control Protocol(TCP) protocol. Software programs are also developed to facilitate transfer of data to the user at remote site. With the web based telemetering system connected to the internet, electrical energy measurements can be accessed globally. The efficiency of the transmission channel is important for the success of both SMS and web based telemetering systems.

Keyword : Telemetry system; remote sites; GSM

I. INTRODUCTION

There is an impending rise in operations costs due to the expansion of customer base. Therefore, the need to implement a system that can cut down on the annual expenditures incurred as a result of the process of taking readings manually is crucial to the company. Moreover, this traditional manual reading process is affected by the outside world whereby weather conditions, roads and transport conditions and other human factors play a huge role in the accessibility of the areas where measurements are to be taken. All these factors, affect the efficiency of meter reading process. A telemetering system that is based on both internet and mobile phone communication systems is thus to be designed. This system addresses the above mentioned difficulties together with the issue of human error which is prone to occur when an operator is taking meter readings. The telemetering system combines computer network technology and the wireless communication technology to improve the efficiency and reliability of electricity meter reading process, reduce the operating cost of the power company, avoid human error and enabling optimized modern management of the company. With the introduction of digital technology, analogue electromechanical meters have been replaced by digital electronic meters. This digital technology provides a good platform for the implementation of Automatic Meter Reading(AMR) system as it involves using an electronic system[1,2].

It must be noted that the concept of telemetering systems can be applied in many areas today, from meteorology to space science, water management, medicine and even military intelligence. However, this paper describes a telemetering system whose purpose is to measure electrical energy consumed by a particular consumer. Efficiency and reliability in retrieving the reading of a meter in the AMR system has proved to be a major challenge in the past. Many methods and technologies that use Power Line

Carrier (PLC) communications, Supervisory and Data Acquisition (SCADA), Ethernet, internet Wi-Fi, Bluetooth, RF module, ZigBee have initially been developed to demonstrate the reliability, efficiency and effectiveness of AMR[3,4]. The above mentioned methods have proved to be either too expensive to implement and operate, they require complex setup of infrastructure as is the case of SCADA or are prone to error and reliability issues due to noise in the transmission line or weather condition. Rapid development of the GSM infrastructure in the past few decades has made wireless AMR system more reliable and possible. Therefore, focus will be aimed at the design of a system that will be able to take meter readings from a remote site and transmit these readings to a central station so that billing can be done by utilizing the GSM technology.

II. LITERATURE REVIEW

2.1 Measurement of energy consumed

At the measuring point, current needs to be stepped down to low values before they are allowed to flow to the microcontroller without damaging the device. For high current values, a current transformer of say 1000/5A can be used. By this, the microcontroller can be programmed to recognize that when it reads a value of 5A, then it knows that this is 1000A, therefore the value of current that will be transmitted to the central station is 1000A. This is for the case of heavy consumers of electricity. The flow of data in the measuring unit is as follows;

- 1- Analog input signals: In this case the input signals to the measuring unit is the current.
- 2- The Analog to Digital converter(AD), is part of the meter measuring system which generates calibrated instantaneous digital value of the current from the analog input signals. For this paper, this ADC is in the Arduino microcontroller device.

2.1.1 Data preparation

The processor determines the mean digital values from the instantaneous values and current generated from the ADC. These mean values are averaged for one second in each case. The mean values in one second are; active power, and current.

2.1.2 Signal processing

The microcontroller calculates the following measured quantities from the mean values provided by the signal processor:

- Mean active power in one second.
- Current in one second.

2.2 Simulation using Proteus software

A simulation of our work is carried out using Proteus software. This is carried out using the following set of components;

1. Resistors.
2. A liquid-crystal display(LCD).
3. Power supply.
4. A load of 240 Ohms.
5. An Arduino Uno.
6. Capacitors.
7. ACS712T Hall Effect current sensor.

Current measurement

Current measurement is achieved using the ACS712T (20A). This current sensor is connected in series with the load to facilitate current measurement. The ACS712T is a sensing device that provides an economical and precise way of sensing AC current passing through it using the hall-effect principle. The ACS712T is based on hall-effect. According to this principle, when a current carrying conductor is placed in a magnetic field, a voltage is generated across its edges perpendicular to the directions of both the current and the magnetic field.

Due to the presence of Lorentz force (force due to the combination of the magnetic and the electric forces), the current distribution is no longer across the hall element and thus a potential difference is created across the edges perpendicular to the directions of both the currents and the field. This voltage is called the hall voltage.

The ACS712 device consists of a precise, low-offset, linear hall sensor circuit with a copper conduction path that is located near the surface of the die. When current is applied through the copper conductor, a magnetic field is generated and this is sensed by the hall-element. The strength of the magnetic field is proportional to the magnitude of the current through the conductor. The signal conditioner and filter circuit which are on the chip stabilize the induced hall voltage to appropriate level so that it can be measured through an ADC channel of the microcontroller.

Terminals of the conduction path are completely electrically isolated from the sensor leads. The ACS712T therefore eliminates the risk of damaging the current monitoring circuit as a result of high voltage on the conduction side.

Since our research involves use of low frequency AC, 50Hz, an RC filter circuit is added at the output of the ACS712 device. This is useful to improve the signal to noise ratio. It must be noted that no resistor is connected in the RC filter, this is because the ACS712 contains internal resistor connected to the output of the on-chip signal amplifier. Therefore simple addition of an external capacitor between the filter pin and the ground would suffice. Since the bandwidth decreases with increasing capacitance, the datasheet of the ACS712 recommends to use 1nF for the capacitor to reduce noise under normal condition.

2.2.2 Output of the ACS712

The ACS712-05B can measure current up to $\pm 20A$ and provides an output sensitivity of $100mV/A$ (at $+5V$ power supply). This means that for every $1A$ increase in the current through the conductor in the positive direction, the output voltage also rises by $100mV$. At zero current, the output voltage is half of the supply voltage ($V_{CC}/2$). The voltage at zero current is found to be $2.4V$ when Proteus software is used in simulation. This value is close to the half way value of $2.5V$. This is the offset of the ACS 712 current sensor.

The ACS712 provides a ratio output in that the zero output current and the device sensitivity are both proportional to the supply voltage, V_{CC} . This feature is useful since the ACS712 is used with an ADC and A/D conversion depends on the stability if the reference voltage used in the ADC operation. The ACS712 has a voltage stabilizer which makes the output to be constant at $2.5V$.

Care must however be taken when working with the ACS712 sensor as it is susceptible to stray magnet fields. The following conditions could affect the value of current being sensed;

1. Stray field resulting from current flowing in a printed circuit board or an external current carrying conductor that is close to the ACS712.
2. External current carrying conductor is on the same plane as the current sensor.

Fig.1 below shows the absolute current error (in A) versus the distance of the hall element from the primary conductor (in mm) for different current values, in A.

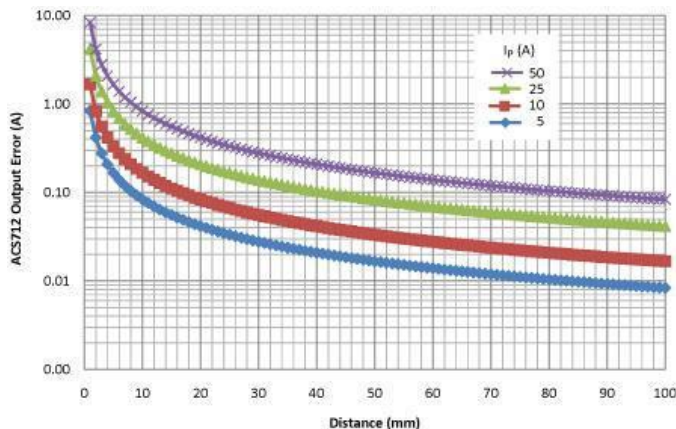

Fig.1 Absolute Output signal error versus distance between the hall element and the External PCB conductor at various levels of current

Shielding must therefore be done on the hall element to prevent stray magnetic fields from interfering with the measurements being taken.

2.3 Time measurement

Time is important since energy consumed is directly proportional to the period of time that the load is connected to the supply and is drawing current.

To measure time, no external hardware is needed as the Arduino has an inbuilt timer. The millis() function is used in the code. What this function does is that it returns the number of milliseconds since the board begin to run the program. Therefore from the instant the program is run, time starts to be taken into consideration.

With this functionality, the meter will give real time energy consumption readings which can then be transmitted.

2.4 Data processing

By scanning the mean values per second (active power, voltage, frequency, power factor), the microprocessor forms related measured quantities. This is done by the ATmega 328 on the Arduino Uno board. These measured quantities are then displayed on an LCD display. A remote readout is also ready to be carried out at this point.

2.4.1 The Arduino Uno R3 microcontroller unit

The Arduino Uno is used to process the data readings and send them to the GSM module for transmission. The Arduino is a microcontroller board based on the ATmega328P. It has 14 digital input/output pins; 6 of which can be used as Pulse Width Modulation(PWM) outputs. It also has 6 analog inputs, a 16MHz quartz crystal, a Universal Serial Bus(USB) connection, a power jack, an In-Circuit Serial Programming (ICSP) header, and a reset button.

2.5 Transmission of measurements

The GSM module is interfaced with the microcontroller as shown in Fig.2 to ensure exchange of information on the measured quantities. In this case, the GSM module obtains information on the measured quantities from the microcontroller. A serial communication at some predetermined baud rate ensures communication between these

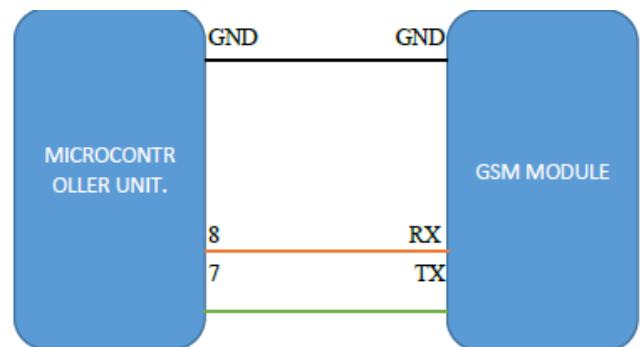

two devices.

Fig.2 Interfacing of the GSM module and the microcontroller

The measuring unit has a unique serial number that makes it possible to interrogate it specifically and obtain all the information on the quantities being measured. This therefore provides real time access to measured quantities.

The GSM module used is the SIM 900A. This is an ultra-compact and reliable wireless module made by SIMcom that works well with the Arduino microcontroller unit. It is a complete dual-band GSM/GPRS module in the Surface Mount Technology(SMT) type and allows us to benefit from the small dimensions and cost-effective solutions. It has SMT pads and uses a single-chip processor integrating ARM926EJ-S. The module delivers the GSM/GPRS 900/1800MHz performance for voice, SMS, data and fax with low power consumption. With a small configuration of 24mm x 24mm x 3mm, the module can fit many space requirements for our applications.

2.5.1 Sending data using SMS

After calculations of power and energy consumed done by the microcontroller, the data is now ready to be sent to the central station.

Here, code is also written to make the SIM900A start operating in SMS text mode hence make it possible for the GSM module to send SMS to the mobile phone subscriber that is also specified. It must be noted that GSM module has two modes of operation, the SMS text mode and the SMS Protocol data Unit(PDU) mode. In SMS text mode, the SMSs are represented as readable text while in PDU mode, all SMS messages are represented as binary strings encoded in hexadecimal characters.

Within the code, delays of several seconds are used after every command to give the GSM module enough time to interpret and respond to the commands.

In specifying the SMS content being sent, the program is set such that it called voltage, current and energy outputs from the code used to measure the energy parameters. These outputs are then sent to the specified subscriber as indicated in the code. The received SMS has data on energy consumed, voltage and current values.

2.5.2 Sending data to a web application

ThingSpeak is also used to show the results of energy consumption. ThingSpeak is an open source Internet of Things (IoT) web application that can store and retrieve data using Hypertext Transfer Protocol(HTTP) and TCP protocols over the internet or through local area network. It enables sensor logging applications for various kinds of sensors. With the web application, values of energy consumed in KWh are recorded

online on a real time basis. This data can be displayed in various ways. The one used in this case is a chart displaying energy consumed on the y-axis and the time of the day when the data is collected on the x-axis. This web application is advantageous because once the data is uploaded, it is stored in a database and can be queried on a specific date range for the purpose of analysis or whatever the user wants it for.

To upload energy consumption readings, a program is written for making the GSM module to transmit the measurements of energy consumed in KWh to ThingSpeak web application in real time.

In the code, a command that sought information about the registration status and access technology of the serving cell is written. This is important as it checks whether the SIM card can actually perform the tasks needed. These tasks include GPRS capability. Code that also attaches packet service is written, then the GSM module is set for single IP connection and the Access Point Name(APN) set according to the Internet Service Provider(ISP) used. For our case, we use Airtel APN. The GPRS is then enabled and an IP address obtained through the appropriate AT command as shown in the code. A TCP connection is then started to a remote address which for this case is api.thingspeak.com, the web application that would display the results remotely.

With the above settings made, data on electrical energy consumption is sent to the web application using the specified ATention(AT) command. The data is then ready for analysis from the web application.

2.6 Final design schematic diagram

The final design diagram is shown in Fig.3.

III. METHOD

In this section, the method used to implement the design is discussed using the following steps;

1. Measurement of energy consumed.
2. Transmission of the reading.
3. Reception of the reading.

To measure energy consumed, the current and voltage values are taken into consideration. The voltage value is taken as 240V, 50Hz which is the standard value of single phase voltage. This is the value of voltage that is be used throughout this paper.

Current drawn on the other hand keeps changing depending on the load connected to the meter. Therefore changes in current determine the amount of energy being consumed per hour. The power factor for low power consumers does not go low easily since the currents drawn are low.

It must be noted that the load used in this paper is a purely resistive load, therefore the voltage is in phase with the current. This means that the power factor will always be 1 as the cosine of 0 is 1. The waveform for power will therefore always be

positive and never negative for this resistive load. This means that power will always be dissipated by the resistive load, never returned to the source as is the case with reactive loads. For the high power consumers, reactive loads are mostly connected. This affects the power factor value.

Once the reading has been taken, it is processed by a microcontroller in the meter then transmitted to a central station using GSM technology. The GSM module has a Subscriber Identification Module(SIM) card which facilitates this transmission process.

The reading is then received either through SMS or to a web application. In this paper, the readings are received through SMS and also via a web application. With this, real time access to the readings of the meter can be obtained. However, to minimize too much traffic in the servers for a real world practical implementation, the meter can be programmed to send meter readings after every 15minutes.

IV. RESULTS AND DISCUSSION

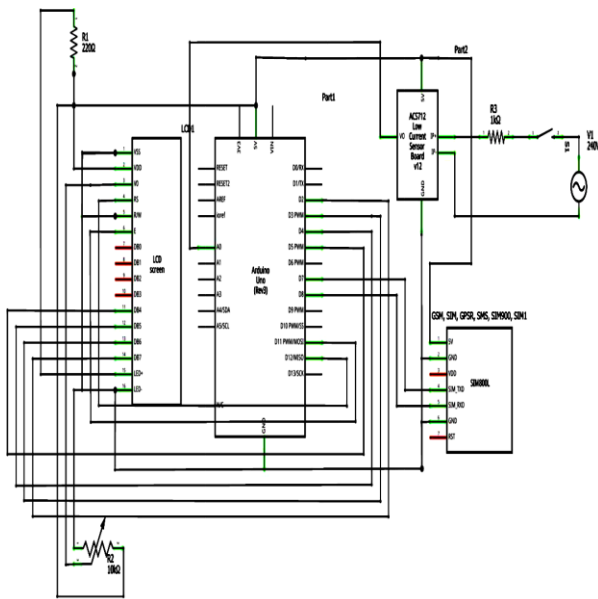

Fig.3 Final design

The results in this paper are the measured quantities of current and energy consumed when different loads are connected. It is seen that a larger load draws more current and consequently consumed more energy. This phenomenon can be seen from the chart in Fig.4 showing energy consumption when different loads are connected.

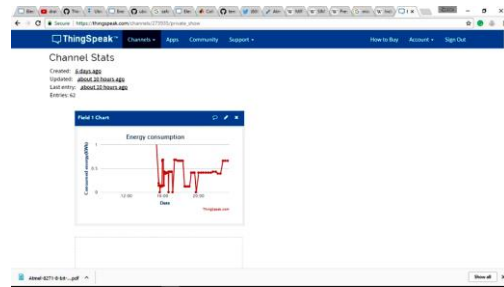

Fig.4 Chart showing energy consumption

From Fig.4, it can be seen that there is a variation on the energy consumed with time. The 100W load which is the largest load used for this paper, consumed an average of 0.66KWh. This can be seen on the chart at about 1800hrs while the 60W load consumption is at about 0.41KWh which can be seen on the chart at 2000hrs. It can also be observed that the energy consumed is fairly constant for any particular load. This means that the current drawn did not vary immensely for one connected load which is what is expected. In the calculation of energy consumed, the period of time for which the bulb is ON is 5hours. This is so as to ensure that the value of energy consumed is significantly larger for the purpose of recording the consumption.

From calculation;

$$P=V \times I$$

For the 100W load, with the supply voltage at 240V, 50Hz, the calculated value of current that should be drawn ignoring any losses is as follows;

$$I= P/V=100W/240V=0.4167A$$

The measured current was found to be 0.55A. The difference between these two values is found to be 0.133A. The 60W load on the other hand has the following calculated values of current;

$$I=60W/240V=0.25A$$

This value is slightly different from the measured value of 0.35A. However it must be noted that the reading recorded when there is no current flowing is actually 0.12A, meaning that the ACS712T exhibits a zero error of 0.12A. Taking this error into consideration this, the value of current being drawn by the 100W load is

$$0.55-0.12=0.43A$$

This makes the percentage error to be;

$$\begin{aligned} & \frac{[(\text{Calculated value} - \text{Measured value})/\text{Calculated value}] \times 100}{=} \\ & = [(0.4167 - 0.43)/ 0.4167] \times 100 = 3.2\% \end{aligned}$$

While for the 60W load, the actual current measured is $0.35 - 0.12 = 0.23A$ and percentage error for this value is therefore 8%.

The small differences in these values are as a result of errors introduced by a difference in the supply voltage. This voltage is assumed to be constantly at 240V. This might not be the case at all times as this value could go down slightly thereby contributing to the difference in the two values of the currents. As mentioned earlier, the values of energy consumed recorded on this particular chart are for a load that has been connected to the power supply for a period of 5hours. For cumulative energy meter recording, the chart shown in Fig.5 shows measured energy consumption for a connected load of 60W over a period of 9 hours.

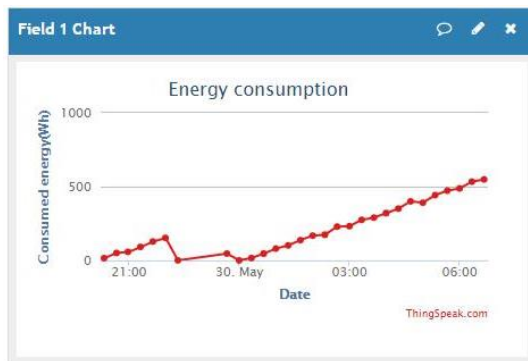

Fig.5 Chart showing meter reading as seen from the web application

. From the chart in Fig.5, it is observed that between midnight and 6am, the energy consumed increased steadily. This is because between this periods of time, the 60W load is connected to the supply and therefore consumes a total of 524Wh or 0.524KWh. The readings recorded on the web application can be seen from Table 1. It is also seen that the load is turned off at around 1927hrs and at 2052hrs. The utility company officer at the central location, must take this effect consideration so that when calculating the energy consumed for this particular consumer, only the peak values are summed. The total consumption according to the chart is therefore 1217.11Wh or 1.217KWh as seen in Table 1.

For all these values of energy consumed, the current measured is found to be 0.35A. When you consider the 0.12A zero error value, then the actual value of current is 0.23A. Comparing this to the calculated current value of 0.25A, we get that the two are very close. Table 1 Meter Readings on Web application at intervals of 10Minutes

Table 1 Meter Readings on Web application at intervals of 10Minutes

Created_at	Entry_id	Consumption (Wh)
2017-05-29 18:45:59 UTC	113	127.95
2017-05-29 19:08:01 UTC	114	152.31
2017-05-29 19:27:56 UTC	115	0.16
2017-05-29 19:38:57 UTC	116	15.37
2017-05-29 20:44:44 UTC	117	46.05
2017-05-29 20:52:47 UTC	118	0.05
2017-05-29 20:56:31 UTC	119	0.05
2017-05-29 21:00:26 UTC	120	0.05
2017-05-29 21:03:44 UTC	121	0.05
2017-05-29 21:09:09 UTC	122	0.15
2017-05-29 21:20:11 UTC	123	16.17
2017-05-29 21:31:13 UTC	124	32.16
2017-05-29 21:42:14 UTC	125	45.87
2017-05-29 21:53:16 UTC	126	58.05
2017-05-29 22:04:18 UTC	127	80.16
2017-05-29 22:15:20 UTC	128	91.57
2017-05-29 22:26:22 UTC	129	101.47
2017-05-29 22:37:23 UTC	130	122.04
2017-05-29 22:48:26 UTC	131	137.3
2017-05-29 22:59:27 UTC	132	152.54
2017-05-29 23:10:29 UTC	133	167.77
2017-05-29 23:21:30 UTC	134	173.86
2017-05-29 23:32:32 UTC	135	198.25
2017-05-29 23:54:36 UTC	136	228.72
2017-05-30 00:05:38 UTC	137	231.75
2017-05-30 00:16:39 UTC	138	259.19
2017-05-30 00:27:41 UTC	139	274.42
2017-05-30 00:38:43 UTC	140	304.17
2017-05-30 00:49:45 UTC	141	289.67
2017-05-30 01:00:47 UTC	142	320.15
2017-05-30 01:11:48 UTC	143	335.39
2017-05-30 01:22:50 UTC	144	350.62
2017-05-30 01:33:52 UTC	145	365.86
2017-05-30 01:44:54 UTC	146	400.15
2017-05-30 01:55:55 UTC	147	396.33
2017-05-30 02:06:57 UTC	148	390.99
2017-05-30 02:17:59 UTC	149	426.82
2017-05-30 02:29:15 UTC	150	442.06
2017-05-30 02:51:09 UTC	151	472.53
2017-05-30 03:02:06 UTC	152	487.77
2017-05-30 03:13:08 UTC	153	528.15
2017-05-30 03:35:12 UTC	154	533.47
2017-05-30 03:46:14 UTC	155	548.71
2017-05-30 03:57:15 UTC	156	958.74
TOTAL ENERGY CONSUMED		1217.11

The readings are also obtained remotely through SMS. The photo in Fig.6 shows meter readings as received through SMS.

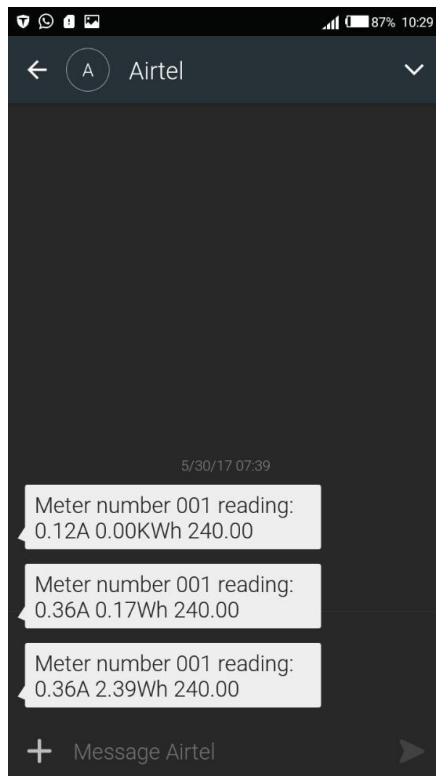

Fig.6 Screenshot of a meter reading as received by SMS

This image best depicts the zero error that is talked about earlier. It is seen from the first reading that no load is connected yet, the recorded current value is 0.12A. In the code, an if statement is written so that if the value of current is less than 0.12A, then the meter would take this value of current as zero. Hence the reading of KWh above is 0.00. This would therefore take care of the problem where the meter records energy consumption in a case where no load is consuming any energy. The resistance of the connecting copper conductors may have contributed to the flow of this current when the load is off.

V. CONCLUSION

The telemetering system was designed using the Arduino Uno which has Atmega 328P microcontroller as the processing unit. An ACS712T (20A) current sensor was used as the current measuring unit while the GSM SIM 900A was the transmitting unit. The loads used were a 100W and 60W bulbs. Simulations were done on Proteus to test the working of the measuring unit with Arduino Uno. As demonstrated, real time measurements of current and energy consumption were transmitted using the GSM module to a mobile subscriber number and data on energy consumed uploaded to a web application called. ThingSpeak.com. With this the objectives of the paper were fulfilled. The zero error exhibited from the measuring unit was

taken into consideration while taking calculations of current drawn by the loads. Through this, it was seen that the percentage error of the measurements was quite small.

REFERENCES

1. K. Jacob, and V. Ramanujam, "Telemetry in power systems," IETE Journal of Research, Vol.29, Issue 8, PP.373-377, 1983.
2. M. Jamil, F. Munir, A. Khan, and ; A. Mirza, "Telemetering & billing system for spatially distributed electrical power clients, " IEEE Conference of E-Tech, Pakistan, 2004.
3. T. Ratniyomchai, U. Jaithong, and T. Kulworawanichpong, "Power line carrier for power telemetering, "International Journal of Electrical and Computer Engineering Vol.5, No.8, PP. 975-978, 2011.
4. E. Önler, C. Soner, M. Aytac and H. İlker, " Development of telemetering system for electric powered vehicle, " International Journal of Current Research, Vol. 8, Issue 9, PP.38715-38719, 2016.
5. Damara TP, Mustaqim A, Devyce A, Adawiyah R. "JAYUS" Meja Payung Solar Cell. Jurnal Teknik Elektro dan Komputer TRIAC. 2021 May 10;8(1):23-5.
6. Rahman F, Sulistiyanto S. Prototipe Palang Pintu Parkir Otomatis dan Informasi Parkir Kendaraan Roda Empat di Pondok Pesantren Nurul Jadid dengan Sensor Infra Red Berbasis Mikrokontroler. Journal of Electrical Engineering and Computer (JEECOM). 2019 Oct 26;1(1).